

# Railway Technology Today 5 (Edited by Kanji Wako)

## How Bogies Work

Isao Okamoto

### Role of Bogie

Railcar bogies usually go unnoticed by rail passengers, but despite their obscurity, they are very important in safe railway operations and perform the following functions:

- Support railcar body firmly
- Run stably on both straight and curved track
- Ensure good ride comfort by absorbing vibration generated by track irregularities and minimizing impact of centrifugal forces when train runs on curves at high speed
- Minimize generation of track irregularities and rail abrasion

To help clarify the basic mechanism of bogies, this article explains bogies used on conventional railcars. Bogies used on shinkansen will be discussed in more detail in the next article in this series.

### Bogie Configurations

#### Types

Bogies are classified into the various types described below according to their configuration in terms of the number of axles, and the design and structure of the suspension.

#### Number of axles

Since bogies run on two steel rails, the minimum structural requirement is an axle and two wheels, which are usually pressed onto the axle (Fig. 1). Bogies are classified into single-axle, two-axle, three-axle, etc., based on the number of axles. The two-axle bogie is most common. In addition to its relatively simple structure, it has the advantage of decreasing the impact of track irregularities on the railcar at the car suspension point, in comparison to the single-axle bogie which transmits the impact to the car directly (Fig. 2). The three-axle bogie has a more complex structure that tends to adversely

Figure 1 Wheel and Axle Set

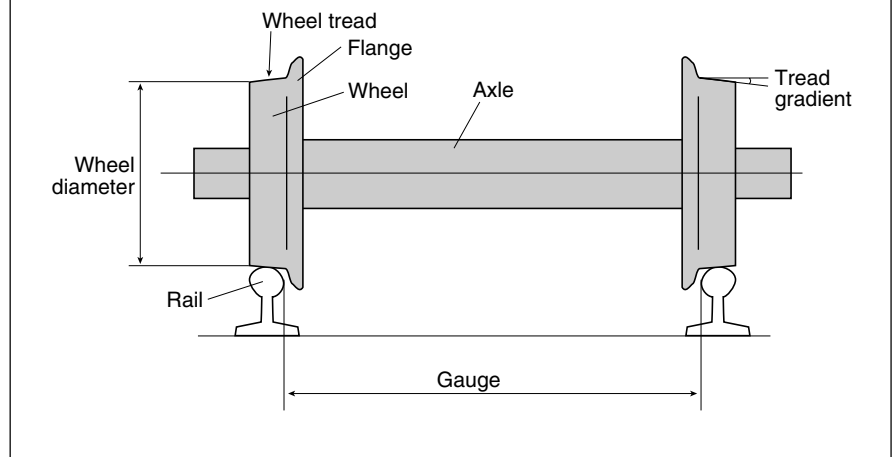

affect the running performance and strength of the bogie frame, so none are used for passenger railcars in Japan today.

#### Non-articulated and articulated bogies

Bogies can be classified into non-articulated and articulated types according to the suspension. Two non-articulated bogies usually support one railcar body (Fig. 3a), but one articulated bogie supports the back end of the forward car and the front end of the rear car (Fig. 3b) as seen in the Spanish Talgo, French TGV,

and some express trains of the Odakyu Line in suburban Tokyo. Although the articulated bogie has some disadvantages, such as a complex structure, increased axle load due to the support of one body by one bogie, and difficult maintenance, it offers various advantages including a lower centre of gravity, better ride comfort because car ends do not overhang bogies, and less effect of running noise on passengers because seats are not over bogies.

Figure 2 Comparison of Effect of Track Irregularity between Single-Axle Bogie and Two-Axle Bogie

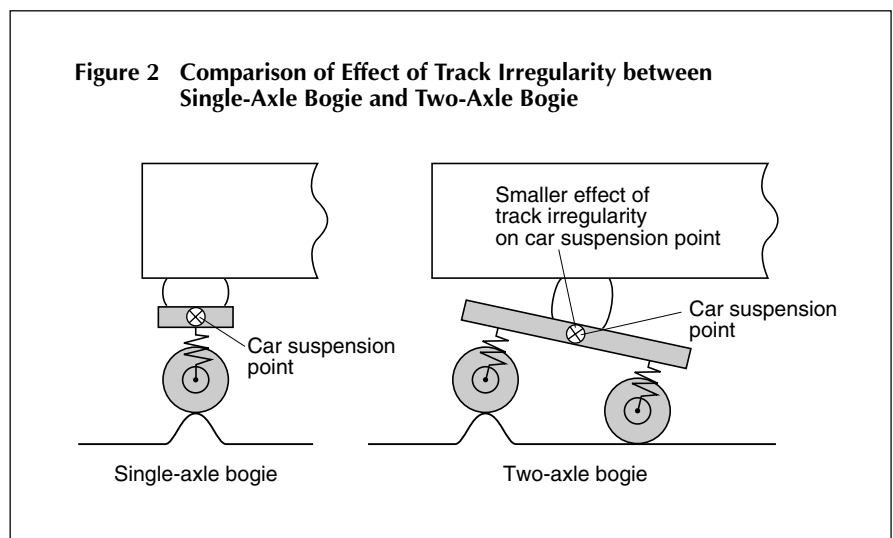

**Figure 3 Non-articulated Bogie and Articulated Bogie**

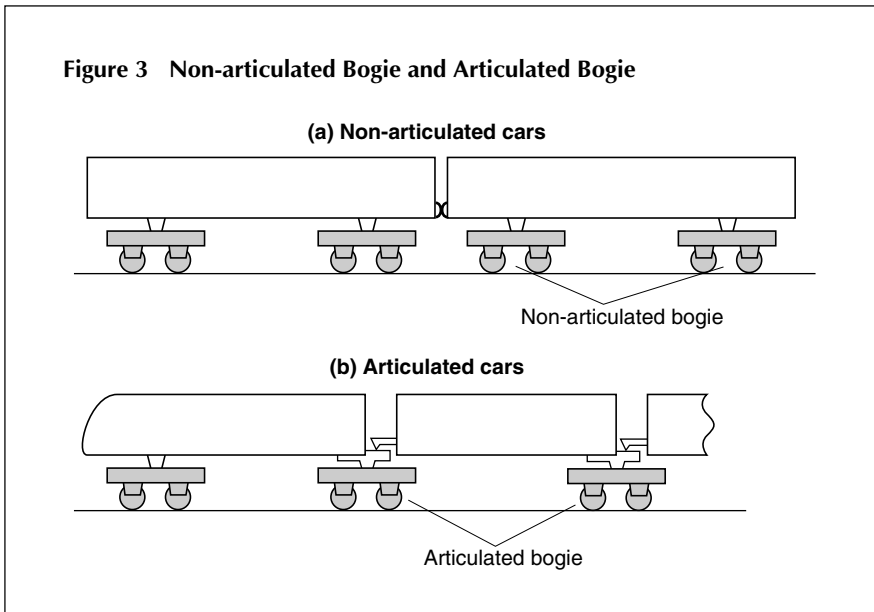

**Figure 4 Swing Hanger and Small Lateral Stiffness Bolster Spring Bogies**

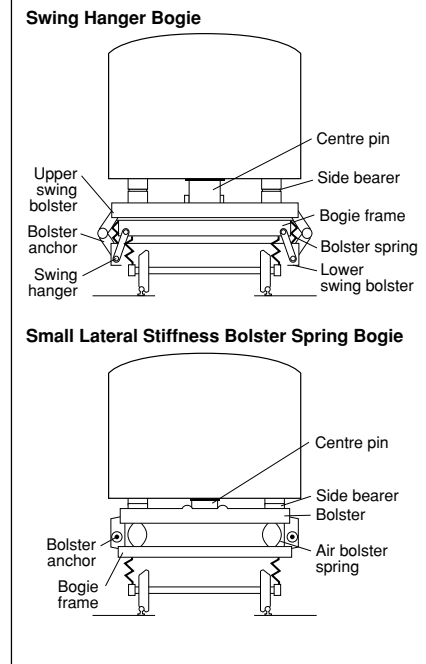

**Swing hanger bogie and small lateral stiffness bolster spring bogie**

Based on the structure of the suspension gear, bogies are classified into two types: the swing hanger type, and the small lateral stiffness bolster spring bogie (Fig. 4). To ensure good ride comfort on passenger cars, the bogie must absorb the rolling motion that passengers are most sensitive to. Conventional swing hanger bogie designs support the body by using lower swing bolster beams suspended from the bogie frame by means of a link consisting of two vertical members that widen toward the bottom, together with bolster springs and upper swing bolster beams (to support vertical movement). Although the swing hanger type (Fig. 5) achieves good ride comfort by minimizing horizontal stiffness of the suspension gear, its maintenance is relatively difficult due to the complex structure and large number of wearing parts. In the 1960s, bolster bogie with air spring that absorbs vibration due to its small lateral stiffness, was developed (Fig. 6). It soon replaced the swing hanger type and was used in the first shinkansen in 1964, contributing greatly to their size and weight reduction. Most recent bogies are of the small lateral stiffness bolster spring bogie type because of its simplified suspension design.

**Bolster and bolsterless bogies**

Bolster and bolsterless bogies (Fig. 7) are differentiated by their suspension gear. The bolster bogie was developed first. A fundamental characteristic of the bogie is that it must rotate relative to the body on curves, while retaining high rotational resistance during high-speed running on straight sections in order to prevent wheelset hunting (Fig. 8) that reduces ride comfort. To achieve these characteristics, the bolster bogie has a centre pivot that serves as the centre of rotation, and side bearers that resist rotation. In the 1980s, a bolsterless bogie was commercialized to improve performance by

reducing the number of parts and the bogie weight (the bolsterless bogie for shinkansen was commercialized in the 1990s). In recent years, most narrow-gauge and shinkansen cars use the bolsterless bogie, which permits rotational displacement on curves through the horizontal deformation of bolster springs (also known as secondary suspension springs)

**Figure 5 Swing Hanger Bogie**

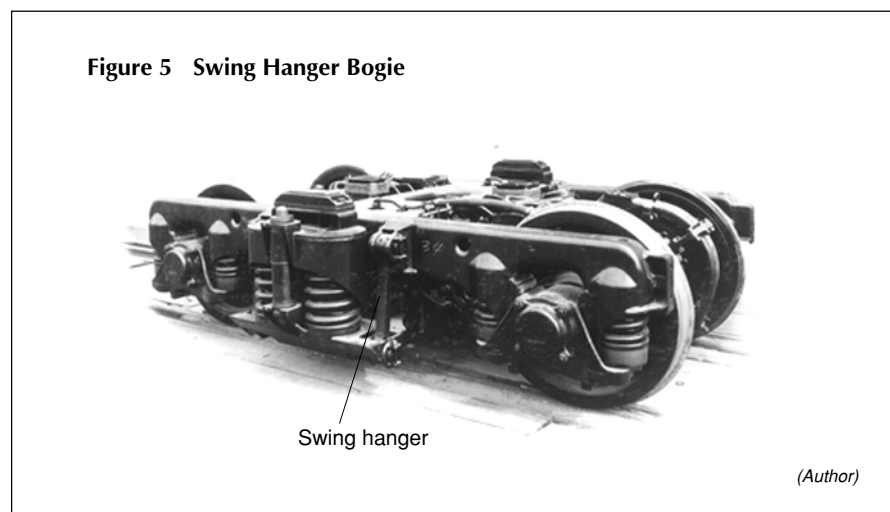

**Figure 6 Lateral Stiffness Bolster Bogie**

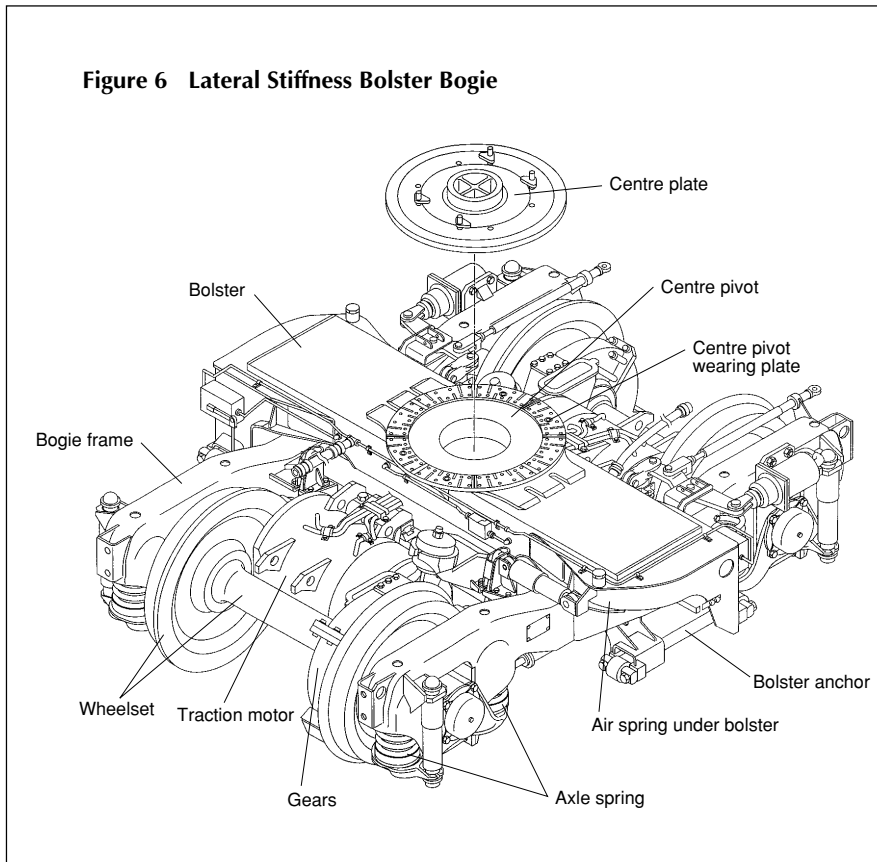

discussion focuses on the bolsterless DT50 type (Fig. 9) which is widely used in commuter passenger railcars of JR companies. The DT50 was first commercialized in 1985 by the former JNR when it was used for the Series 205 railcars.

**Suspension gear**

The suspension gear (bolster spring, traction transfer device, anti-yawing damper, and lateral damper) plays an important role in supporting the body, allowing the bogie to rotate relative to the car body on curves, isolating the body from vibration (including high harmonics) generated by the bogie, and transmitting traction force from the bogie to the body. For these purposes, the bolsterless bogie has air springs that permit large horizontal displacement, as well as a traction transfer device (classified into permanent-link type, the Z-link type and laminated-rubber type) at the virtual rotational centre of the bogie for transmitting the tractive force to the car. In addition, the bolsterless bogie used for express trains and shinkansen has anti-yawing dampers (Fig. 7) at the outer side of the side beam of the body and bogie frame (parallel to the side beam) to prevent wheelset hunting that reduces ride comfort.

Coil springs were originally used as bolster springs to support the body, but in the 1960s, air springs were commercialized for railcars in Japan and were used for high-speed trains. Since the 1980s, they have been used for commuter and short-distance trains in order to take

**Figure 7 Bolster and Bolsterless Bogies**

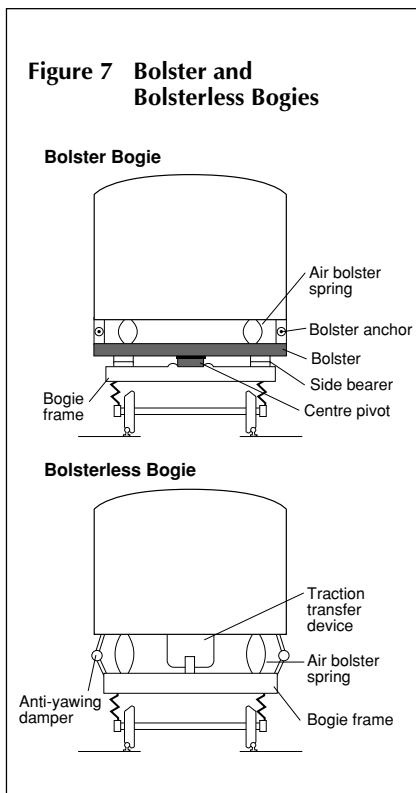

on both sides of the bogie. Rotation is resisted by longitudinal anti-yawing dampers on both sides of the bogie, resulting in better rotational resistance than conventional side bearers.

**Basic Bogie Elements**

This section describes key components and parts of the bogie, including their structure and performance. However, it should be noted that the parts vary widely according to the bogie type, and this

**Figure 8 Wheelset Hunting**

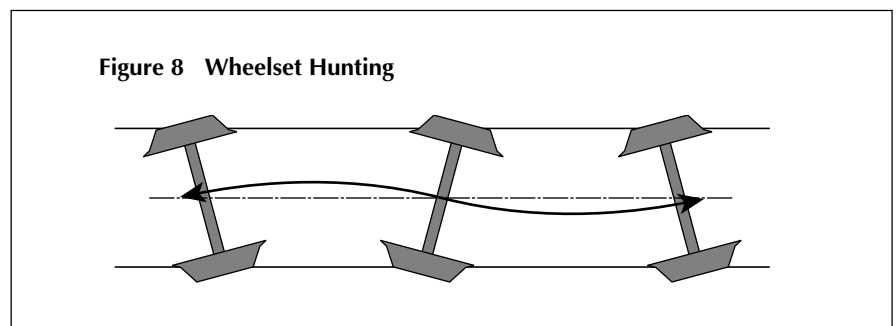

advantage of their improved ride comfort and ability to maintain body height.

### Bogie frame

The bogie frame accommodates various bogie equipment and is generally fabricated by welding together two side beams and two cross beams into an H-shaped frame, (Fig. 10). In 1955, compound side beams were developed using press welding and this structure is used to manufacture most bogie frames in Japan. The thickness of the side and cross beams was increased from 6 mm (used in some frames around 1960) to 9 mm. It was increased again to 12 mm in the 1970s, when some bogie frames of express trains were found to have minor faults. However, since the DT50, as a result of simpler construction and improved welding technology, bogie frames use 8 or 9 mm plates to reduce weight. Finally, around 1980 (1976 for shinkansen), the material of major bogie frame members for narrow-gauge railcars was improved from SS400 (rolled steel for general structures) to SM400B (rolled steel for welded structures).

Some bogie frames since the DT50 use seamless steel pipes for cross beams to reduce weight and cost.

### Axle box suspension

This device supports the axle via the bearing from the bogie frame. It is a critical component determining the running performance of the bogie, ride comfort and bogie frame construction, due to the suspension method and support rigidity. Various designs are used (Fig. 11). The pedestal swing spring design supports the axle box using sliders around the pedestal on the bogie frame and was used widely in a variety of railcars of the former JNR. While its construction is simple, the sliders wear with time, creating play in the suspension and cause wheelset hunting, so it is not suitable for high-speed operation. The IS type was developed for

**Figure 9 DT50 Bogie for Series 205 EMU**

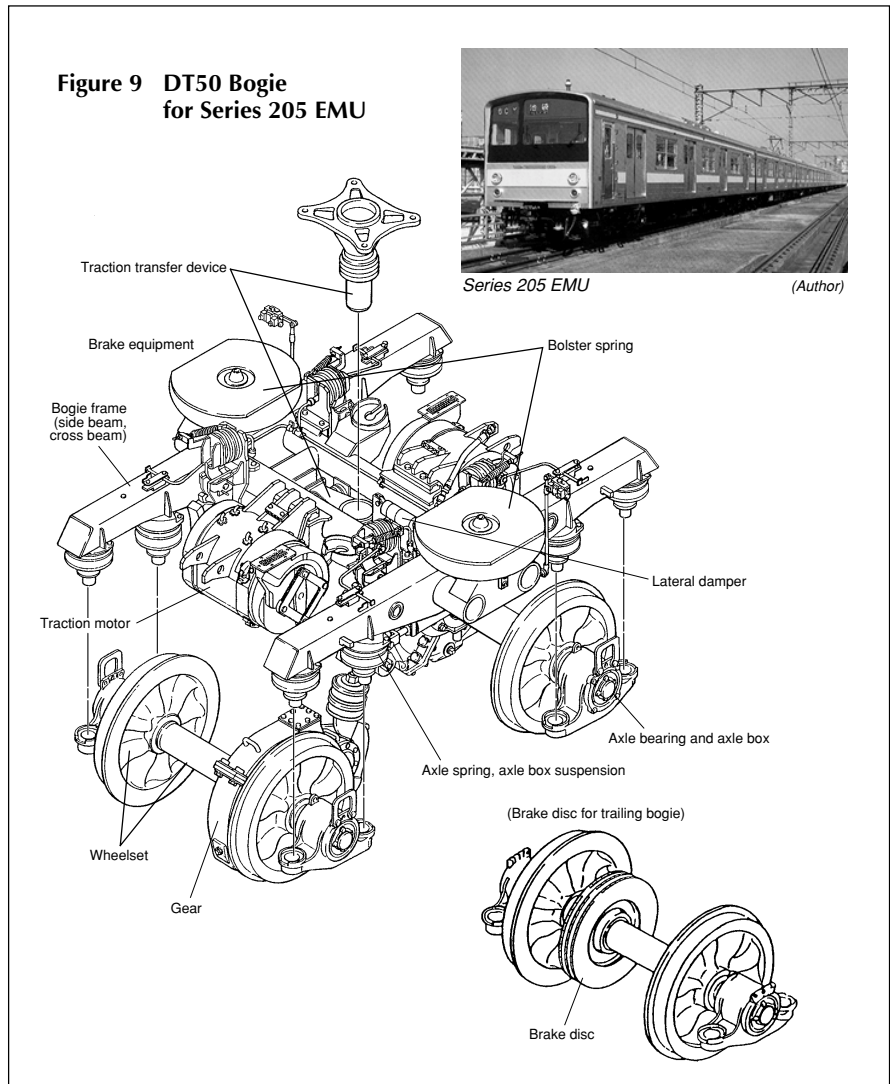

**Figure 10 Bogie H-Frame**

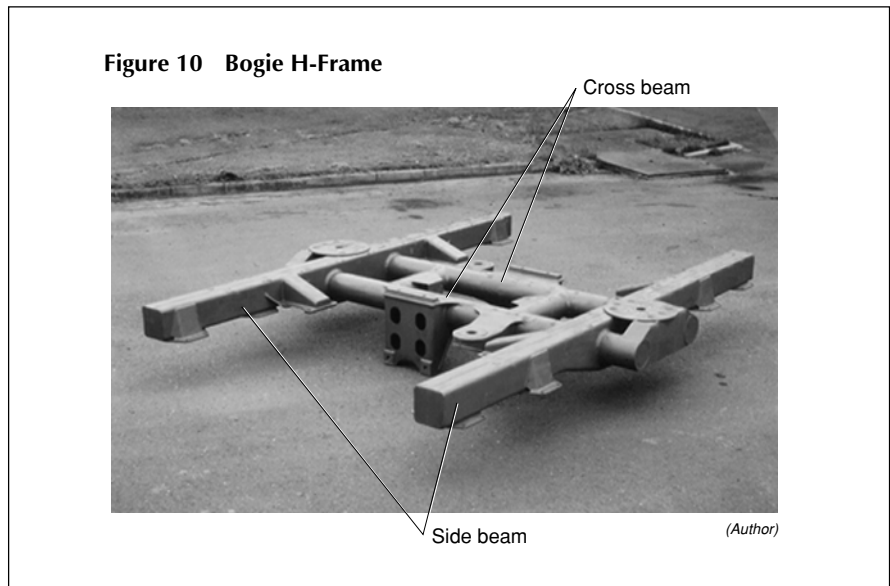
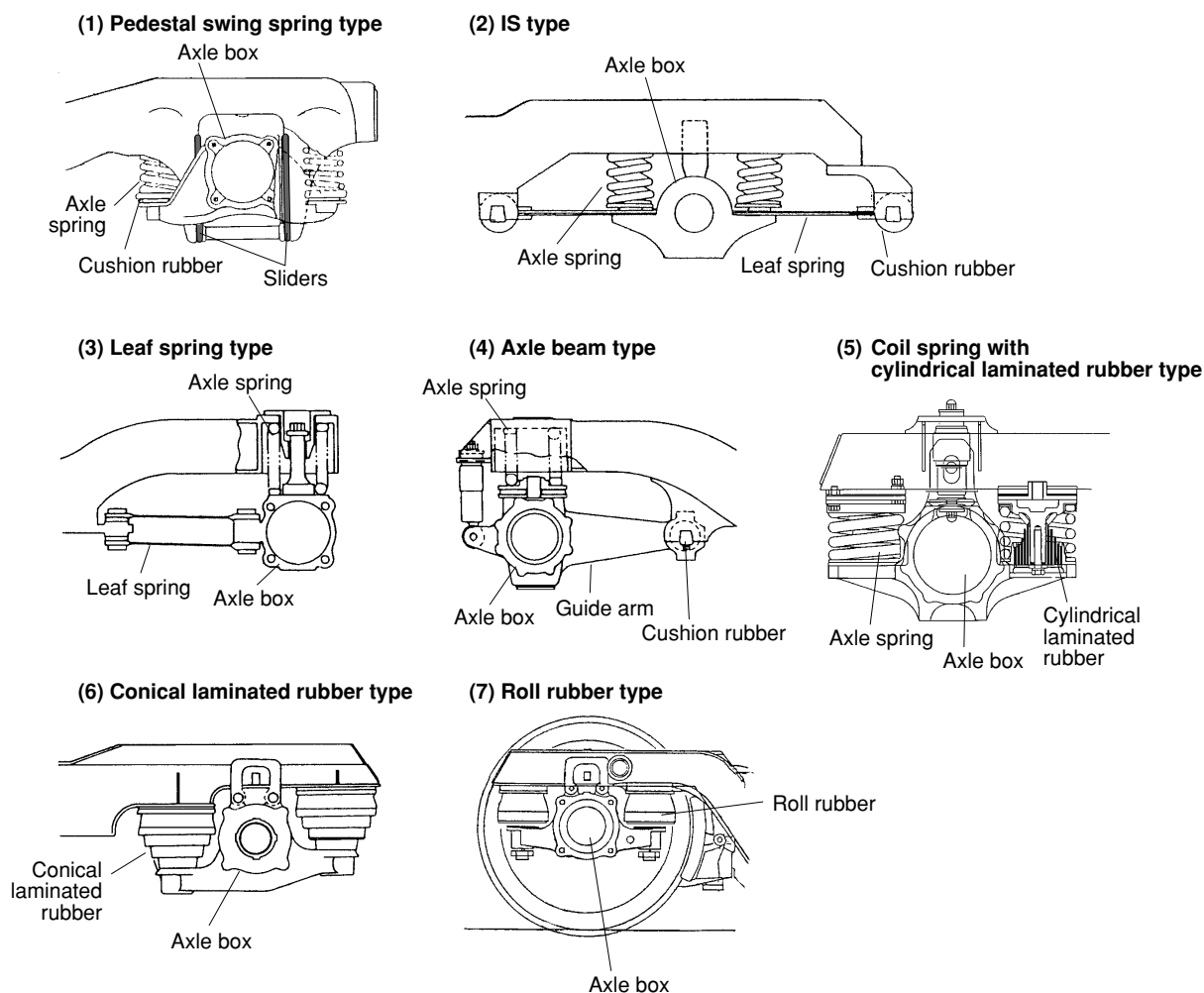

Figure 11 Various Axle Box Suspensions



shinkansen and its good cushion rubber stiffness effectively eliminates play between the axle and bogie frame. However, it has several disadvantages, such as increased bogie frame length and severe maintenance requirements for leaf springs. As a result, recent bolsterless bogies for shinkansen use other types, including the coil spring with cylindrical laminated rubber type. Similarly, narrow-gauge railcars are increasingly using the conical laminated rubber type, the roll rubber type (serving both as the axle box suspension and axle spring) and axle beam type in order to simplify construction and reduce manufacturing costs.

### Wheels, axles and bearings

Wheels of conventional railcars are a solid rolled type, and generally 860 mm in diameter when new. Corrugated wheels (Fig. 12) with a corrugated outer face have been commercialized to boost rigidity, while reducing plate thickness and weight. They have been used for commuter and short-distance trains since the 1980s. The wheel tread is heat-treated and has the profile shown in Fig. 13. Wheels are susceptible to mass imbalance, which causes vibration of the axle and wheel and is transmitted to the body, producing uncomfortable resonance at certain speeds. To prevent this, efforts

have been made since 1984 to hold the imbalance per wheel to below 25 kgf-cm and to balance the wheels when pressing them onto the axle.

The axle is generally solid, but hollow types are used for weight reduction without affecting bending strength. Hollow axles with a central void were used for high-speed electric railcars and passenger cars in the late 1950s, but their use was abandoned due to manufacturing problems. Around 1975, to improve reliability, a hollow axle was developed by boring a solid axle (Fig. 14). It was first used in 1981 to make lighter drive axles for high-speed diesel railcars

**Figure 12 Corrugated Wheel**



(Author)

operating in Hokkaido. It was later used for bolsterless bogies of shinkansen, contributing to reduced unsprung mass. Axle bearings have traditionally combined a cylindrical roller bearing (to take radial loads) and a ball bearing. Since 1965, a single sealed flanged cylindrical roller bearing (able to take both radial and thrust loads) has been used increasingly to facilitate bearing weight and size reduction as well as to obtain longer periods between overhaul.

**Transmission**

The transmission consists of gears and flexible couplings to transmit motive power generated by the motor or engine to the axle. For EMUs, the nose suspension device, which supports the traction motor with the bogie frame and the axle (via support bearings), was used until the 1950s (Fig. 15a). The nose suspension device was large and heavy to withstand vibration generated by the axle and also due to the slow speed of the motor, resulting in large bogie mass and unsprung mass. Around 1957, the parallel cardan driving device (Fig. 15b and c) was put into service by mounting a smaller, high-speed motor on the bogie frame supported by axle springs and transmitting the motive power to the gear via a flexible coupling. It enabled reduction of the bogie wheelbase as well as significant size and weight reduction of the entire bogie, and contributed greatly to the development of shinkansen and conventional express cars. DMUs use either electrical or mechanical transmission. While the former is used primarily in other countries, the latter is used mostly in Japan. In this case, the motive power from the engine is transmitted via a torque converter and flexible couplings to the axle using a right angle cardan driving device (Fig. 15 d).

**Figure 13 Basic Wheel Tread Profile for Narrow-Gauge JR Lines (upper) and Circular Arc Wheel Tread Used Widely Today (lower)**

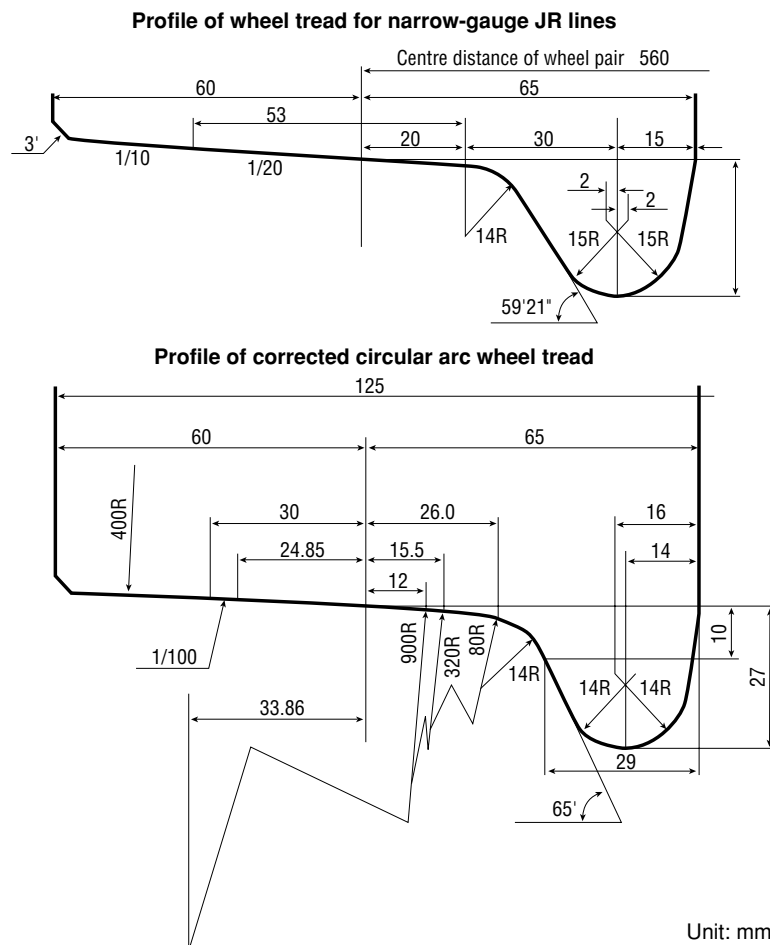

**Figure 14 Hollow Bored Axle**

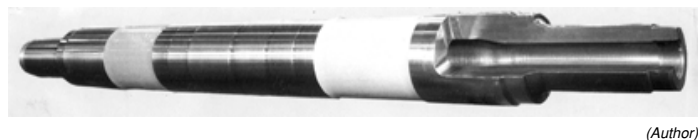

(Author)

**Brake equipment**

The brake is used to stop at the desired position. This section focuses on mechanical braking equipment such as wheel tread brakes and disc brakes. Wheel tread brakes use block-shaped brake shoes that are pushed against the wheel tread. Although they have a simple construction, they generate large amounts of frictional heat at high running speeds,

causing the wheel temperature to rise to critical levels. This presents a risk of cracking and makes them unsuitable for high-speed operations. Disc brakes use disks at both sides of the axle or wheels; at braking, the discs are clamped by brake pads on the calipers to impede rotation. Traditionally, cast iron has been used for the disc due to its superior frictional characteristics relative to the pads. However,

recently, forged steel is used for high-speed railcars to prevent disc cracking caused by frictional heating. In Japan, disc brakes were first used on some express trains of the Odakyu Line, and they have been used primarily for trailer cars on narrow-gauge lines. Nevertheless, disc brakes are costly to manufacture and maintain, so commuter (Fig. 9 inset) and short-distance railcars that run at relatively low speeds often use motor braking as a means of halving the number of discs to one (reinforced type) per axle.

**Major Characteristics of Bogies in Recent Narrow-gauge Railcars**

This section focuses on the design and key features of new bogies designed for narrow-gauge lines in Japan, such as the bogie for commuter trains, the pendulum bogie and the steering bogie (used for express trains).

**Bogies for commuter trains**

Since commuter or short-distance trains use a large number of bogies, the design must be simple to cut manufacturing costs and maintenance requirements. As a result, bogies for recent commuter trains mostly use the bolsterless suspension system. As far as possible, straight side beams are used for the bogie frame and seamless pipes are used for the cross beams. Also, conical, laminated rubber, or roll rubber suspension systems are used for the axle box and also serve as axle springs. Otherwise, the relatively simple axle beam suspension type is used. Axle bearings are generally sealed flanged cylindrical roller bearings. Unit brakes are used increasingly as part of the ongoing effort to reduce the number of parts, thereby lengthening the service life between inspection and overhaul.

**Bogies for express trains**

Bogies for express trains have the same design concepts as bogies for commuter

**Figure 15 Transmissions**

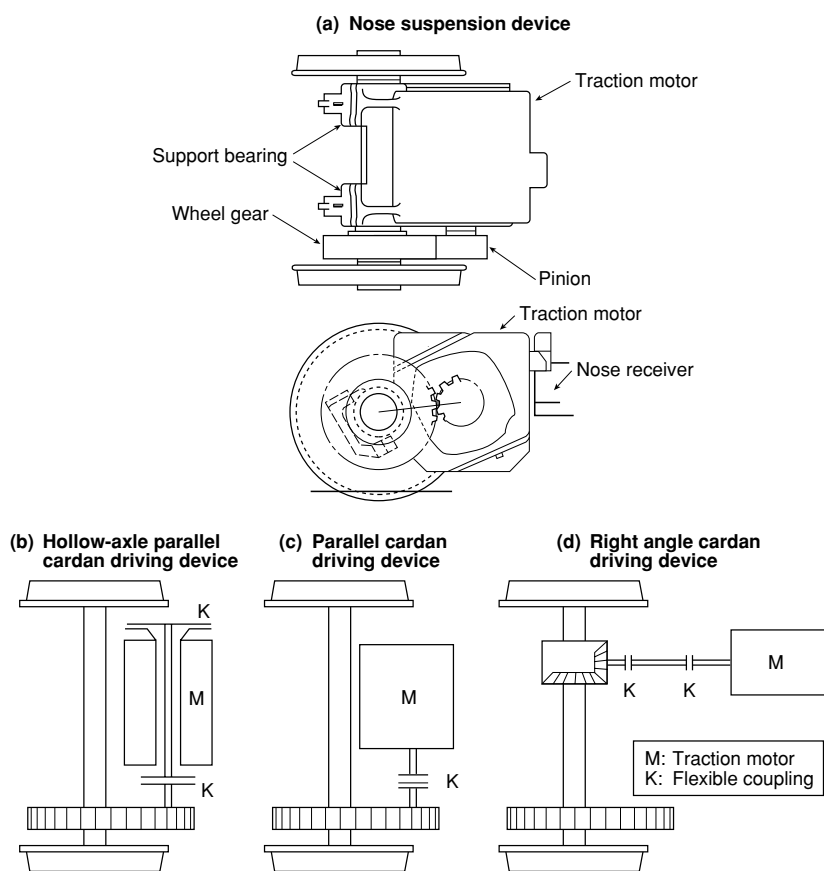

trains in terms of simple construction to cut manufacturing costs and save labour related to maintenance. However, new bogie designs are required to meet the demand for higher speeds, thereby cutting travel times and making trains more competitive with planes and cars. Narrow-gauge lines in Japan are dominated by many sections with tight curves, and travel times can be reduced by increasing running speeds on curves instead of increasing maximum speeds. Two types of bogies have been developed to achieve this aim: the tilting bogie, which increases running speed on curves without affecting ride comfort, and the steering bogie, which permits higher speeds on curves by minimizing the lateral force on the rail. They are described below.

**Tilting bogie**

When a train runs at a high speed over a curve, the generated centrifugal force adversely affects ride comfort by pushing passengers toward the outside of the curve. The tilting car has been developed to minimize lateral forces acting on passengers by tilting the body toward the inside of the curve, rather like a motorcycle taking a curve. In Japan, the first

**Figure 16 Roller Type Tilt System**

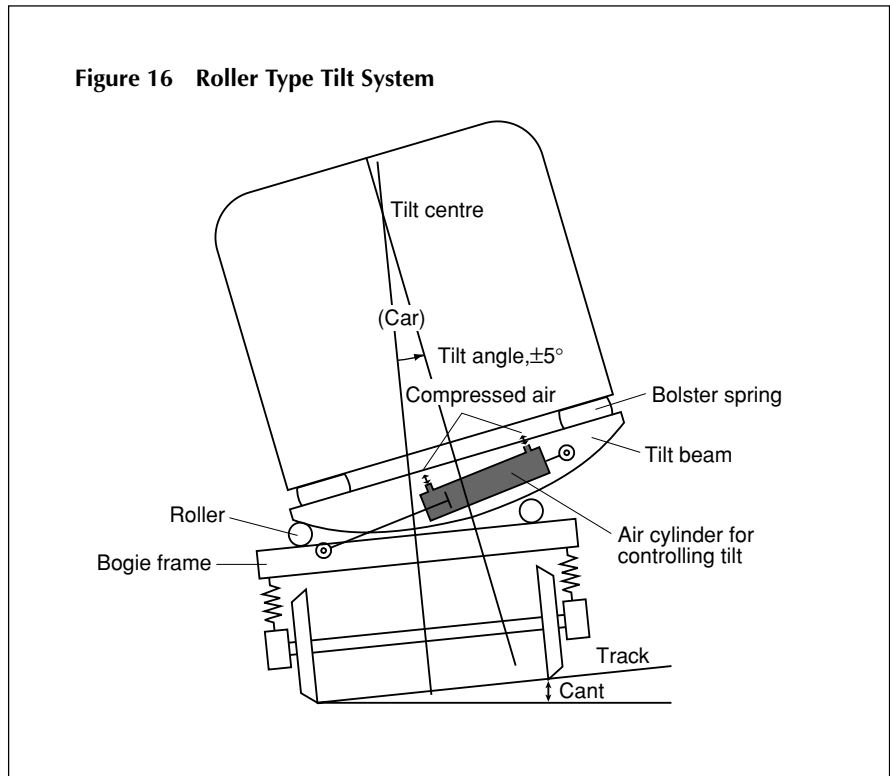

tilt railcars (Series 381) were introduced in 1973 on the western section (Nagoya to Nagano) of the Chuo Main Line. Figure 16 shows the bogie design concept. The bogie consists of a body tilting system supporting the body on two 170-mm diameter rollers and bow-shaped tilting beams with a centre of curvature aligned

with the body tilt centre. When the bogie runs on a curve, centrifugal force acting on the centre of gravity causes the body to tilt up to 5° towards the inside of the curve. This is called the 'roller type, natural tilt system'. The Series 381 railcars were subsequently introduced on other lines (Kisei and Hakubi Lines), often



Test run of roller type controlled tilt system using Series 381 express EMU. Car body is tilted. (Author)



JR Shikoku used the controlled tilt system in its DMU Series 2000 express train (right) and EMU Series 8000 express train. (Author)



**Figure 17 Principles of Controlled Tilt System**

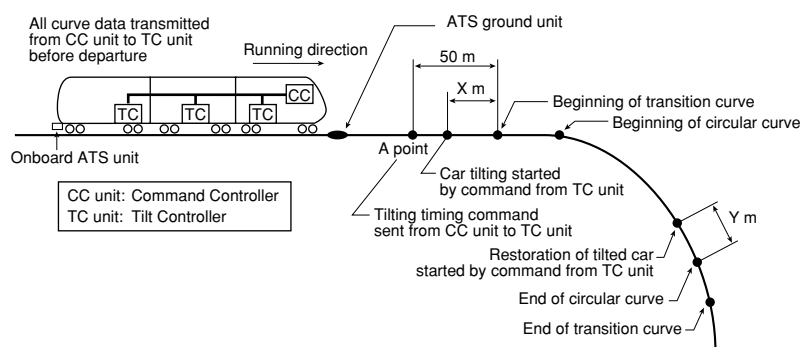

**Figure 18 Link-Type Forced Steering Bogie**

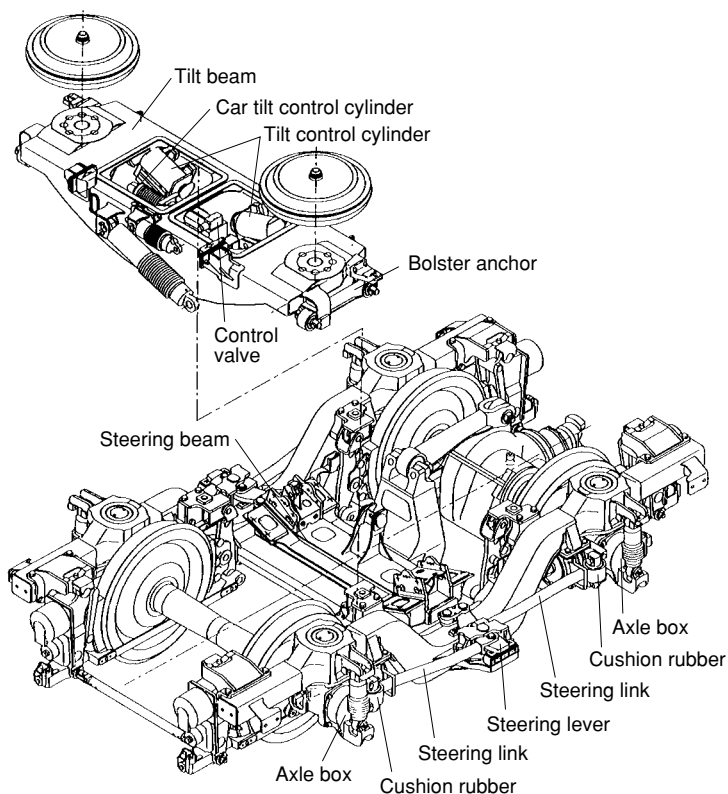

contributing greatly to reduced travel times and improved riding comfort. However, they were not a success on sections with many frequent tight curves where body tilting was either delayed or occurred too abruptly.

To ensure smooth tilting in these circumstances, the 'controlled tilt system' (Fig. 17) was developed. This system incorporates air cylinders into the body tilting system. An onboard controller stores data about all curves on the section where the train operates, including curve radius, alignment, elevation, distance between ATS (Automatic Train Stop) ground units and starting point of transition curves, lengths of transition curves and circular curves, etc. The controller is activated by ATS ground units and controls the timing and degree of body tilting 30 to 40 m before entering curves by referring to the stored curve data and computing the running distance to the curve using the axle revolutions from the nearest ATS ground unit.

The controlled tilt system was first introduced in 1989 on JR Shikoku DMU Series 2000 express trains. It was soon introduced by all other JR companies due to its good reputation including ride comfort.

In fact, the controlled tilt system increased running speeds over curves with a radius of 300 to 600 m from 80–110 km/h achieved by the natural tilt system to 85–120 km/h.

In addition, the body tilting system was modified to reduce tilt resistance by using a large number of smaller bearings, in place of the conventional rollers, thereby achieving a smaller lighter bearing guide type tilting mechanism, which is used in recent tilt cars.

**Steering bogie**

As a train runs on a curve at high speed, the wheels exert high lateral force on the rails causing wear and tear of wheel flanges and rails, and resulting in derailling in extreme cases. This lateral force

can be reduced by various methods, including use of self-steering bogies.

As shown in Fig. 1, normal wheels are press-fitted onto the axle and have a tread gradient. This gradient provides some degree of steering over a curve by allowing the centre of the axle to move towards the outside of the curve as a result of the centrifugal force. The steering bogie is designed to make the most of this ability by reducing the stiffness of the axle box suspension and increasing the tread gradient to maximize the difference in diameter between left and right wheels on the same axle. These features allow the wheels and axle to move more freely without sacrificing running stability. This concept is used in most recent bogie designs, ranging from those for commuter trains to express trains. Nevertheless, with this self-steering design, care should be taken to avoid excess reduction of stiffness of the axle box suspension and excessive tread gradients. These concepts may be effective in reducing lateral force on the rail, but they can adversely affect running stability due either to small changes in tread gradient caused by wear and tear, or to slight play in the wheel suspension, both of which risk generating wheelset hunting.

To deal with the drawbacks of the self-steering bogie, the link-type forced steering bogie has been developed (Fig. 18) and is currently used on JR Hokkaido Series 283 DMU express trains. The operating principle is to transmit rotational displacement of the bogie relative to the body to the axle via a linkage, so the axle centre line is aligned on the radius of curvature (Fig. 19). This mechanism cuts lateral force on the rail to one half or one third that of conventional bogie designs (Fig. 20).

**Figure 19 Alignment of Link-Type Forced Steering Bogie on Curved Section**

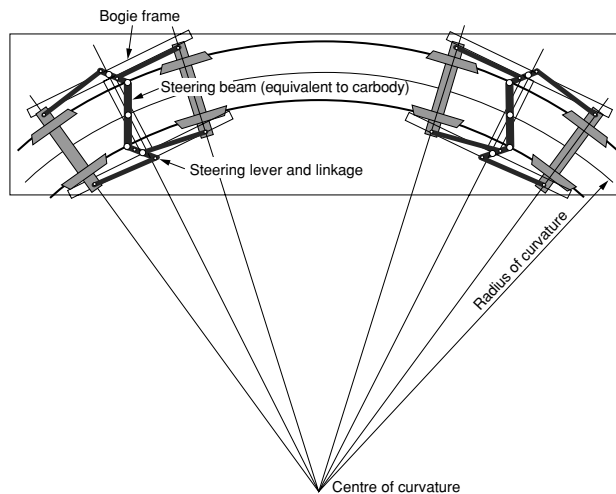

**Figure 20 Lateral Forces of Link-Type Forced Steering Bogie and Non-Steering Bogie on Rails**

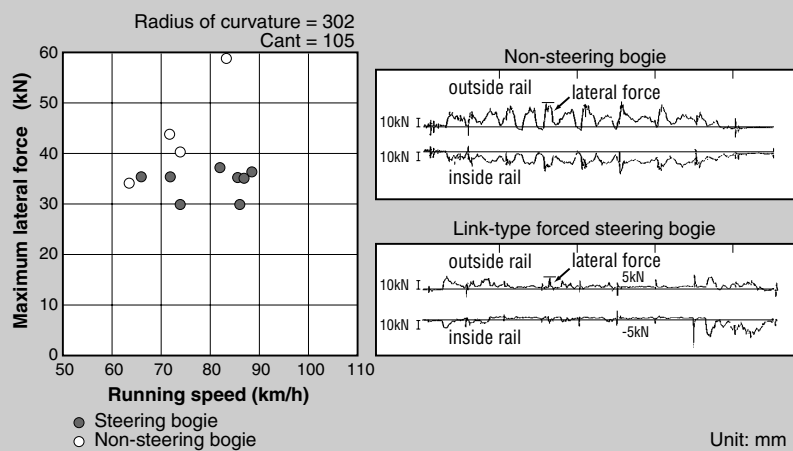

## Kanji Wako

Mr Kanji Wako is Director in Charge of Research and Development at RTRI. He joined JNR in 1961 after graduating in engineering from Tohoku University. He is the supervising editor for this series on Railway Technology Today.



## Isao Okamoto

Mr Okamoto is General Manager of the Vehicle Technology Development Division of the JR Railway Technical Research Institute. He joined JNR in 1972 after obtaining a masters in mechanical engineering from the graduate school of Waseda University. He worked in the Rolling Stock Design Office of JNR before transferring to RTRI.